



# FIREGUARD

## Swing Check Valve Resilient Seated Flanged Ends

FCF01



### Valve Standard

Conforms to AWWA C508, Clear Waterway  
Fusion bonded coating comply with AWWA C550

### Working pressure

200PSI / 250PSI / 300PSI

### Working Temperature

-10°C to 110°C

### Flanged Ends

ANSI B16.1 CLASS125/B16.42 CLASS150/B16.  
EN1092-2 PN10/PN16/PN25  
BS10 Table D/Table E

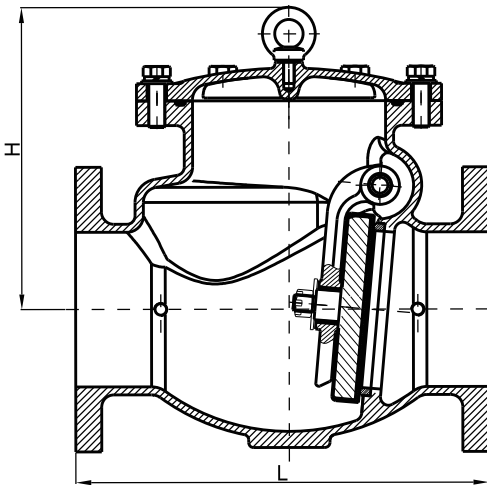

### Materials List

Part Name	Material	Specification
Body	Ductile Iron	ASTMA536 65-45-12
Cover	Ductile Iron	ASTMA536 65-45-12
Clapper	Carbon Steel	A36+SS304+EPDM
Clapper Arm	Ductile Iron	ASTMA536 65-45-12
Hinge Pin	Stainless Steel	AISI 304
Seat	Bronze	ASTM C84400

### Dimensions(mm/inch)

SIZE	mm	50	65	80	100	125	150	200	250	300
	inch	2	2½	3	4	5	6	8	10	12
L	mm	203	254	279	330	356	406	495	559	660
	inch	8	10	11	13	14	16	19.5	22	26
H	mm	117	128	132.5	222.5	290	297	365	417.5	453
	inch	4.61	5.04	5.22	8.76	11.42	11.69	14.37	16.44	17.83

\*\*\*Note: Subject to change without prior notice due to products optimization.

FIREGUARD GLOBAL LTD. Unit 11, Chancel Industrial Estate, Newhall Street, Willenhall, WV13 1NX, United Kingdom

www.fireguard-uk.com

**valve**